

HAYSSSEN R300 FLOW WRAPPER

A modern, single or twin jaw flow wrapper that delivers jam-free reliability, operator-friendly features, and intuitive HMI functionality.

APPLICATIONS / INDUSTRIES:

- ✔ Single & Trayed
- ✔ Baked Goods
- ✔ Cookies
- ✔ Donuts
- ✔ And more

WHY CHOOSE THE HAYSSSEN R300?

BUILT FOR RELIABILITY. BACKED BY LIFETIME SUPPORT.



Trouble-Free Operation — The ergonomic, open-channel infeed design allows for quick, tool-less changeovers, improved cleaning access, simplified film threading, and easily adjustable settings.



Dependable Performance — Advanced servo-driven system automatically detects and clears jams without stopping, status lighting delivers real-time alerts, and Allen-Bradley components ensure fast parts availability to maximize uptime.



Empowers Operators — Modern OpView™ HMI enables operators to be self-sufficient through guided onboarding, intuitive navigation, clear functional parameters, and step-by-step instructions to maximize machine speed.

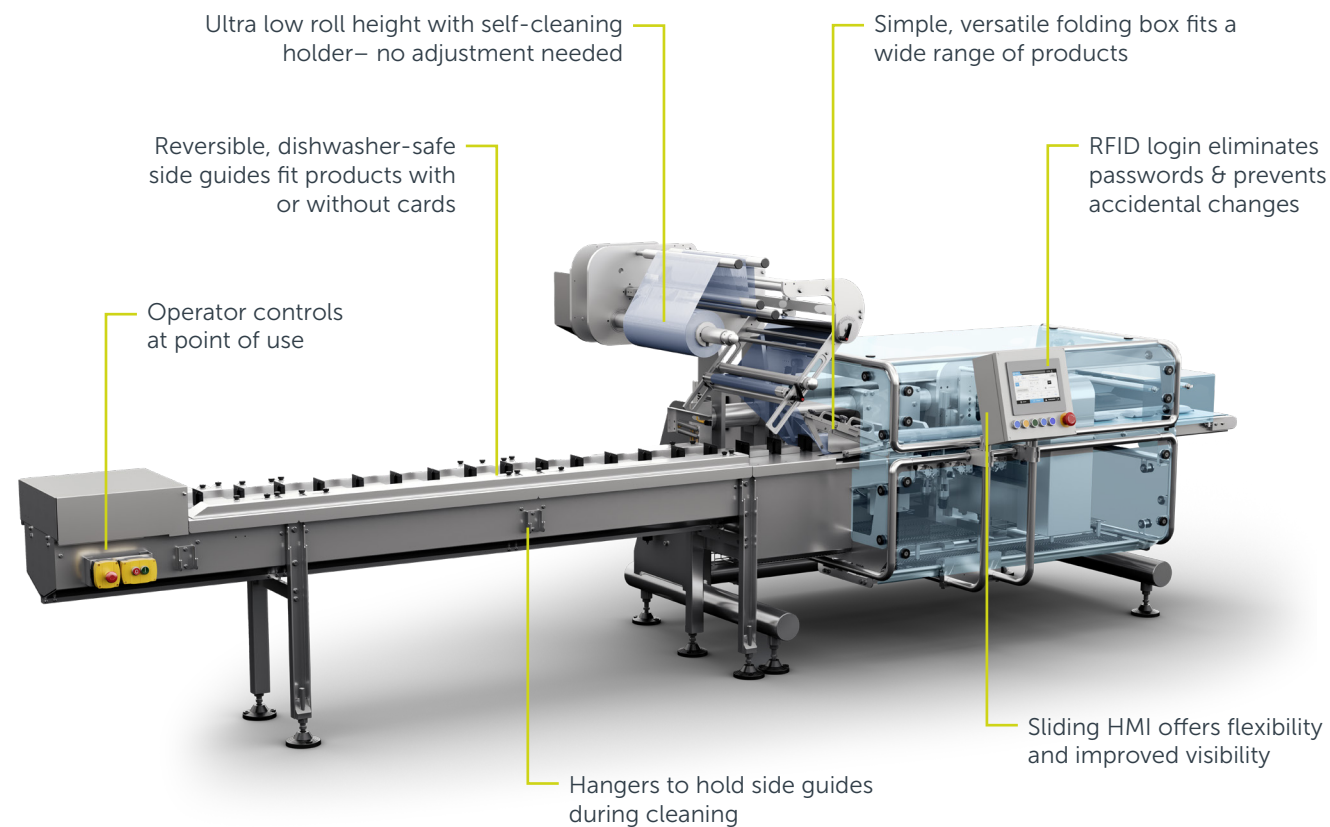

EASY | TRUSTWORTHY | SEAMLESS INTEGRATION

The Hayssen R300 flow wrapper is built for bakery operations that demand consistent output and dependable quality. Its thoughtful design prioritizes ease of use, productivity, and intelligent automation—helping producers maintain efficiency while reducing operator effort.

With unique anti-jam technology, the R300 delivers steady, reliable performance run after run. Engineered specifically for single and trayed goods, it produces high-quality packages with every cycle. And for products that require extra care, an optional infeed feature helps preserve the integrity of delicate items throughout the wrapping process—ensuring they reach customers looking just as good as when they left the bakery.

When integrated with upstream and downstream equipment, the Hayssen R300 becomes part of a cohesive, performance-guaranteed packaging system. Our project management team oversees every step, delivering a seamless, turnkey solution tailored to your production needs.

Specifications			
Production Speed	Up to 200ppm	Anti-jam Technology	Yes
Infeed	Lugged	Cleaning	IP65 wash down infeed, wipe down wrapper
Pack Styles	Pillow, Gusset	Electrical	480V, 3Ph
Jaws	Rotary, Single or Twin	Integrations	Upstream and downstream equipment
Unwind	Single Spindle	Dimensions (inches)	196 L x 70 W x 66 H
Tool-less Changeovers	Yes	Dimensions (mm)	4988 L x 1780 W x 1680 H



Talk to us about your operation.
Let's design a solution together.

MORE THAN MACHINES. A PARTNERSHIP FOR LIFE.

At BW Packaging, we don't just build machines — we're your lifetime partner in production success. Our global service network, parts availability, training and upgrades all work together to keep your machines running for years to come.



bw **PACKAGING**
a **barrywehmler** company

bwpackaging.com